



## OWNER'S MANUAL

Installation, Operation, and Maintenance Information

Family of Diesel Oxidation Catalyst (DOC) Mufflers

Manual No. P478598 Rev 3

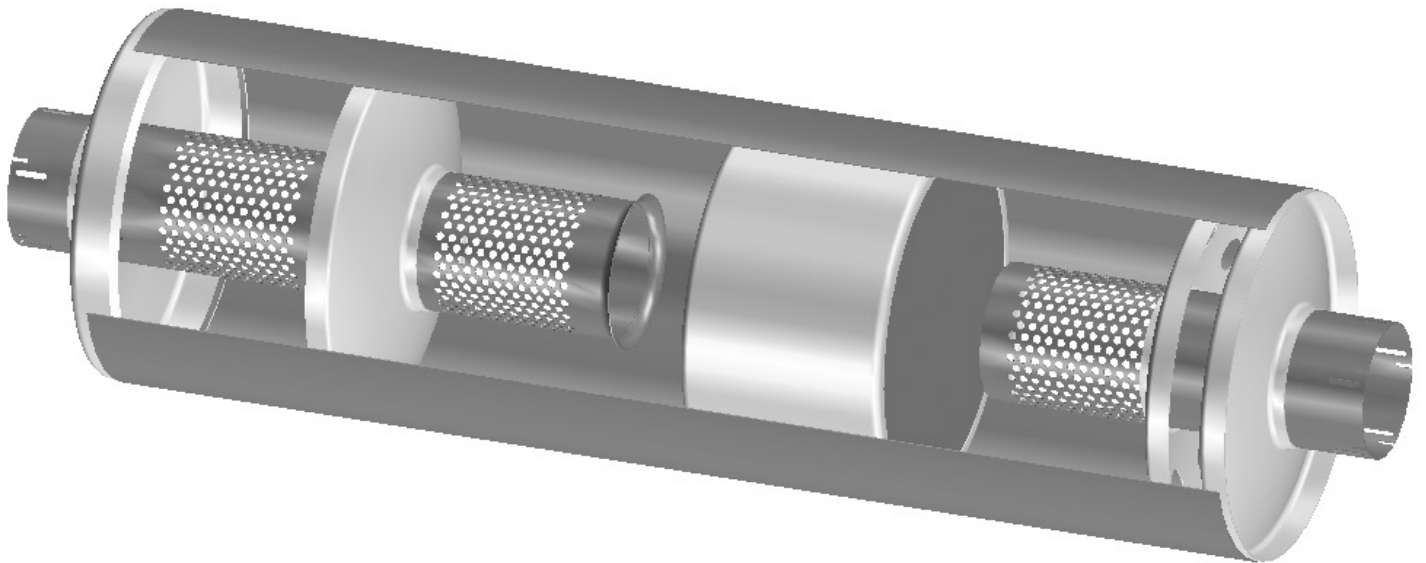

This manual is property of the owner. Leave with the unit when installation and start-up are complete. Clean Diesel Group reserves the right to change design and specifications without prior notice.

Do not make any system modifications or adjustments that would alter the original retrofit installation. Modifications may not meet California ARB Executive Order requirements, be considered illegal devices and may result in denial of warranty coverage.

Consult your Clean Diesel Group certified emissions dealer if you have questions regarding the installation, operation, maintenance or warranty.

Illustrations are for reference only as actual product may vary.



**This is the safety alert symbol. It is used to alert you to potential personal injury hazards. Obey all safety messages that follow this symbol to avoid possible injury or death.**



# Contents

<b>Introduction .....</b>	<b>4</b>
<b>Pre-Installation Requirements.....</b>	<b>4</b>
Selecting the Right DOC Muffler .....	4
Inspect Mounting Hardware.....	4
Minimize Exhaust Tubing Lengths.....	5
Minimize Exhaust Leaks and Plugging .....	5
<b>DOC Muffler Installation .....</b>	<b>5</b>
Vertical Installation.....	5
Remove the Existing Muffler .....	5
Install the DOC Muffler.....	5
Horizontal Installation .....	6
Remove the Existing Muffler .....	6
Install the DOC Muffler.....	6
Device Identification .....	7
Installation Checklist.....	7
<b>Operation, Maintenance and Service Guide for DOC Mufflers .....</b>	<b>7</b>
Operation.....	7
Maintenance and Service .....	7
Conditions that May Plg a DOC Muffler.....	8
How to Check & Clean DOC Mufflers .....	8
DOC Muffler Clean-Out Instructions.....	8
DOC Muffler Disposal Information .....	8
DOC Muffler Warranty .....	8
<b>Activating the Warranty .....</b>	<b>8</b>
<b>Actions and Improper Maintenance That May Void Your Warranty .....</b>	<b>9</b>

## Introduction

Clean Diesel Group's (CDG) DOC Mufflers are designed to reduce harmful emissions from in-use diesel engines. Besides reducing diesel particulate matter emissions by 15-30%, diesel oxidation catalysts (DOC's) mufflers are also effective at reducing hydrocarbon emissions. California has classified several hydrocarbon emissions as toxic air contaminants.

DOC Mufflers are extremely reliable, cost-effective and easy to apply as well as providing substantial benefits in air quality. DOC Mufflers are also maintenance-free with normal operation.

For optimum performance, follow Clean Diesel Group's simple installation recommendations.

<b>NOTE</b>	<b>Follow installation requirements</b>
Installations must meet Clean Diesel Group requirements outlined in this manual to obtain full warranty coverage.	

## Pre-Installation Requirements

Your CDG DOC Muffler includes the following parts:

Qty.	Description
1	DOC Muffler
1	Documentation package that includes this owner's manual, a warranty registration card, warranty statement and engine tag.

CDG's pre-installation requirements are provided below. In order to maximize DOC muffler performance and service life, installation must meet these requirements.

<b>NOTE</b>	<b>Engine Must Meet OEM Specifications</b>
The engine must be inspected by a qualified mechanic to verify the engine is operating within the engine OEM's specifications. If the engine does not meet specifications, necessary repairs must be made prior to DOC Muffler installation. The mechanic must document compliance on the warranty registration form. Failure to comply may void the warranty. The warranty and warranty registration card are separate documents in the documentation package.	

<b>NOTE</b>	<b>Do Not Use Fuels Blended with Lube Oil</b>
Engine oil must not be blended with the engine's fuel since the oil may cause reduced emissions performance and deposits in the catalyst that may cause higher backpressure, plugging and reduced engine performance and void the warranty.	

<b>NOTE</b>	<b>For Electronically Controlled Engines</b>
Electronically controlled engines are certified with a specific fuel and electronic program based on engine configuration and model year. Use only the fuel and electronic program specified for your engine. Using the incorrect fuel and/or electronic program may cause excessive soot generation and catalyst plugging and may void the warranty.	

	<b>CAUTION!</b>
Certain components found in engine lube oil can poison catalysts. To protect against catalyst failure and/or plugging, ensure that the engine is not consuming oil at a rate higher than specified by the engine manufacturer. Use low ash oils, when possible. Do not use fuel blended with lube oil. Check with your local CDG dealer to review additives before use.	

## Selecting the Right DOC Muffler

Be sure you have selected the proper DOC Muffler model. Application of the wrong model will affect exhaust system backpressure. Failure to apply the proper model may cause engine damage and void the warranty.

## Inspect Mounting Hardware

DOC Mufflers weigh approximately 50% more than traditional OEM truck mufflers (45 lbs. vs. 30 lbs. [20.4 kg vs 13.6 kg]). Inspect any mounting system hardware intended for reuse to ensure it is in good condition and can adequately support the added weight. Look for signs of rust, corrosion or fatigue. Do not reuse suspect components. Heavy-duty components should be used.

<b>NOTE</b>	<b>Inspect DOC Muffler Mounting Hardware</b>
A DOC Muffler weighs approximately 50% more than a traditional OEM truck muffler. The mounting system should be inspected to ensure it is in good condition and can adequately support the added weight. Inspect all hardware intended for reuse for rust, corrosion or fatigue. Replace all questionable components with heavy-duty components.	

### Minimize Exhaust Tubing Lengths

The catalyst temperature has an affect on emissions reduction performance. To optimize emissions reduction, the DOC Muffler inlet must be less than 15 ft. (4.6m) downstream from the turbocharger outlet flange when measured along the piping center line. Placement beyond 15 ft. (4.6m) may result in a plugged catalyst and void the warranty.

The catalyst should be mounted as close to the engine as possible, but must be isolated from engine vibration. Do not hard-mount the DOC Muffler directly to the engine.

<b>NOTE</b>	<b>Mount the DOC Muffler Less than 15 ft. (4.6m) from the turbocharger</b>
Mount the DOC Muffler less than 15 Ft. (4.6m) downstream from the turbocharger outlet. Mounting the DOC Muffler beyond this distance may cause plugging and void the warranty.	

### Minimize Exhaust Leaks and Plugging

To maximize emission aftertreatment effectiveness, exhaust tubing should be structurally sound and leak-free. Inspect the exhaust tubing for leaks due to damage or corrosion, and replace defective components. Also look for flaking due to corrosion and/or soot build-up. Loose contaminants can be blown onto the catalyst face and cause plugging, increased backpressure and degraded engine performance.

	<b>CAUTION! Rust, Corrossion and Soot on Existing Exhaust Tubing</b>
If you see any evidence of rust or corrosion on existing tubing between the turbocharger and DOC muffler inlet, replace with new aluminized steel tubing. If reusing existing exhaust tubing, banging and tapping on the tubing may dislodge soot. Be sure to clean out any pipes prior to installing new components. Operate engine at high idle to blow out exhaust pipes prior to the installation of the DOC Muffler. Protect yourself and others from loud straight pipe noise.	

### DOC Muffler Installation

The following section includes separate procedures for vertical and horizontal installations. Please use the procedure that matches your current muffler orientation.

Make sure to review all pre-installation requirements before proceeding with the installation.

#### NOTE

DOC Mufflers may plug if the engine is not properly maintained. This is especially true when operated under low-load or low ambient temperature conditions, idled for extended periods of time or if the engine is not properly calibrated for the specific fuel-type being used. To prevent the occurrence of plugging, engine problems must be resolved prior to installing a DOC Muffler.

### Vertical Installation

#### Remove the Existing Muffler

1. Loosen stack clamp at muffler outlet (top). Remove stack and clamp.
2. Loosen tubing clamp at muffler inlet (bottom).
3. Loosen clamps on flex tubing. Remove clamps, flex and elbow.
4. Remove muffler and heat shield mounting bands.



#### Install the DOC Muffler

1. Inspect the mounting brackets, bands, supports and/or stanchion for any damage, cracks or corrosion. Mounting components must be strong enough to adequately support the additional 15 lbs. (7 kg) weight. Replace any existing mounting parts that appear rusted, damaged or of questionable strength with heavy-duty parts.
2. Place muffler/heat shield mounting bands on DOC Muffler body and finger-tighten. Locate DOC Muffler on mast in position of original muffler. Secure on mast with muffler mounting bands.

	<b>CAUTION! Do Not Overtighten Bands or Clamps on Muffler Body</b>
The catalytic core inside could be damaged if you deform the muffler body by overtightening clamps.	

3. Position flex tubing and clamps onto exhaust tube. Do not tighten clamps until all tubing is assembled.
4. Position inlet elbow and muffler inlet clamp. Locate flex tube so that there are equal lengths of rigid tubing (within the flex) on both ends. Tighten clamps to secure flex tubing and inlet elbow.

**NOTE**

Excessive force on the inlet and outlet piping in conjunction with vehicle vibration can result in stress cracking where the pipe or pipe supports contact the DOC muffler inlet. Failures caused by excessive force are a result of improper installation and may not be covered under the warranty.

- Position clamp over DOC Muffler outlet tube. Insert stack into the muffler outlet and tighten securely. Vertical tailpipes over 4ft/1.2m require additional support. Install a rain cap on all applications to prevent water damage.



**CAUTION! Water from Rain and Truck Washing Can Poison the Catalyst**

Water can also damage the catalyst core retention material in the DOC Muffler. Vertical tail pipes must be fitted with rain cap or curved outlets.

- Install heat shield. Ensure DOC Muffler/heat shield mounting bands are secure.
- Verify that all bolts and fasteners have been sufficiently tightened.
- Operate vehicle and check for exhaust leaks. Repair any leaks.
- Turn off the engine.
- Permanently attach the product identification tag (supplied in documentation package) in a clearly visible location on the engine. CARB regulations require a product identification tag be permanently installed on the engine in a clear, visible location.

**NOTE**

**CARB Requirement**

California ARB regulations require a product identification tag be permanently installed on the engine in a clear, visible location.

- Complete Warranty Registration through the online portal [www.cleandieselgroup.org](http://www.cleandieselgroup.org). Failure to register warranty within 30 days of installation may void the warranty.



**Horizontal Installation**

**Remove the Existing Muffler**

- Loosen clamp at muffler outlet. Remove clamp and tailpipe.
- Remove clamp at muffler inlet.
- Loosen muffler mounting bands and remove muffler.

**Install the DOC Muffler**

- Inspect the mounting brackets, bands, hangers, and supports for any damage, cracks or corrosion. Mounting components must be strong enough to adequately support the additional 15 lbs. (6.8 kg) weight. Replace any existing mounting parts that appear rusted, damaged or of questionable strength with heavy-duty parts.

**NOTE**

**Mounting System Space Allowance**

Allow 1" (25mm) space for engine movement and thermal expansion around the DOC Muffler.

- If the application uses a vertical tailpipe, drill a 1/4" (6mm) drain hole 12-18" (305-452mm) on the pipe from the outlet end of the DOC Muffler.

**NOTE**

**Drain Hole Required on Horizontal Mount with a Vertical Tailpipe**

Horizontally-mounted DOC Mufflers with a vertical tailpipe must have a 0.25" (6mm) diameter drain hole drilled through the lowest point of the pipe, 12-18" (305-452mm) from the outlet end of the DOC Muffler. Rain and truck wash water can poison the catalyst, reducing emission performance. Water can also damage the catalyst core retention material in the DOC Muffler. Vertical tail pipes should be fitted with rain caps or curved outlets.

- Position the DOC Muffler in the mounting bands on muffler and mount in position. Position DOC Muffler so drain hole is at the bottom. Be sure the mounting bands do not cover the drain hole.
- Tighten clamp on muffler inlet.



**CAUTION! Do Not Overtighten Bands or Clamps on Muffler Body**

The catalytic core inside could be damaged if you deform the muffler body by overtightening clamps.

- Install tailpipe and secure clamp on muffler outlet/tailpipe joint.

	<b>CAUTION! Avoid Rigid Mounting of the DOC Muffler</b>
The original equipment muffler should have flexible hangers installed to allow for thermal expansion. If your system does not have flexible hangers, they should be installed.	

- Verify that all bolts and fasteners have been sufficiently tightened.
- Operate vehicle and check for exhaust leaks. Repair any leaks.
- Turn off the engine.
- Permanently attach the product identification tag (supplied in documentation package) in a clearly visible location on the engine.

<b>NOTE</b>	<b>CARB Requirement</b>
California ARB regulations require a product identification tag be permanently installed on the engine in a clear, visible location.	

- Complete the warranty registration through the online portal [www.cleandieselgroup.org](http://www.cleandieselgroup.org). Failure to complete warranty registration within 30 days of installation may void the warranty.

### Device Identification

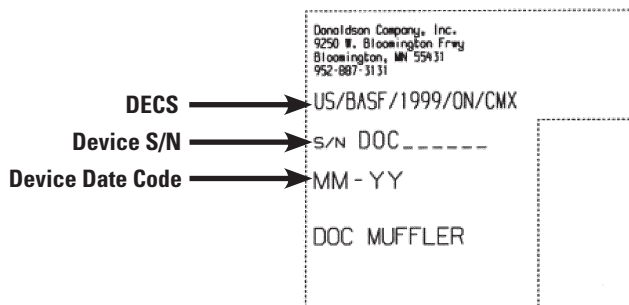
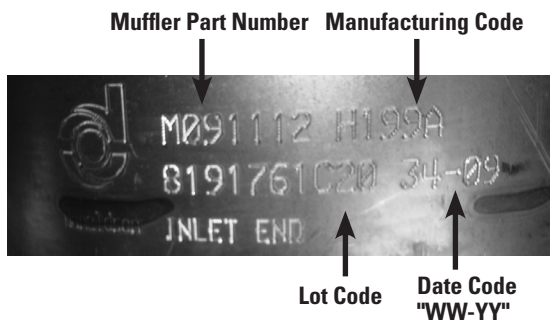

### Installation Checklist

#### DOC Muffler

- DOC Muffler mounted in proper exhaust flow direction
- All DOC Muffler mounting hardware and clamps are tightened
- New hardware and clamps installed per this manual
- No visible exhaust leaks in the system
- Vertical tailpipes over 4 ft./1.2 m require additional support

#### Program Compliance

- Activate your warranty
- ARB engine tag permanently affixed to the engine with RTV silicone in a visible location
- End user has warranty document and this manual for their records

### Authorized Installer Qualifications

All authorized CDG Retrofit Emissions Installers are required to follow all terms and conditions of the CDG Dealer contract. Some of the key requirements are highlighted below.

- Be capable and competent to pre-assess, select and install the proper device, provide training, sales support and service to all CDG VDECS as prescribed in the Installation, Operation, and Maintenance Manuals
- Provide sales and support of the product locally
- Maintain all required compliance documents

Failure of all or any one of the items listed above or in the dealer contract will result in revocation of CDG authorized installer status.

### Activate the Warranty

For regulatory reporting and warranty registration purposes, CDG Company requires the installer/dealer to complete and submit the warranty for the vehicle or equipment owner on our Warranty Registration web site.

A Warranty Registration Worksheet is included in the documentation packet. Register the new installation within 30 days using our on-line warranty registration site at: [www.cleandieselgroup.org](http://www.cleandieselgroup.org)



### Emissions Retrofit Documentation

Retain all emissions retrofit documentation on each vehicle, including:

- Vehicle temperature data / profile form
- CDG response letter that approved the retrofit application
- Date of installation
- Mileage / hours at install
- Installation and owner information
- Part number
- Serial number
- DPF service and cleaning records

## Operation, Maintenance and Service Guide for DOC Mufflers

### Operation

CDG DOC Mufflers are designed and verified for use on most medium- and heavy-duty truck and bus applications. To ensure proper functioning of these products, CDG preventive maintenance and service procedures must be incorporated into your regular vehicle maintenance routines.

### Maintenance and Service

Preventive maintenance recommendations during normally scheduled vehicle maintenance

1. Inspect the DOC Muffler exhaust piping and mounting brackets.
2. Look for leaks, structural failures (cracks) and loose or missing fasteners.
3. Repair or replace defective parts, as appropriate.

### Conditions That May Plug A DOC Muffler

- Engine operation at low load or idling for extended periods of time
- Improper engine maintenance
- Improper engine calibration for the specific fuel type being used

If plugging is suspected because of a noticeable loss of performance or fuel economy, you may want to measure the exhaust system backpressure.

### How to Check for a Plugged Catalyst

1. Weld a ¼"-18 NPT pipe coupling in the exhaust pipe near the DOC muffler inlet and drill 1/8"(3mm) diameter in center of coupling and install a manometer or backpressure gauge with a range of 0-80" H<sub>2</sub>O or 0-6"Hg.
2. Operate the engine until thoroughly warm, run at high idle, no load for 2-3 minutes.
3. Record backpressure with the engine at high idle running at the no load condition.
  - a. If backpressure is less than 40" H<sub>2</sub>O or 3" Hg, it is unlikely the DOC Muffler is involved. Continue to operate the DOC Muffler without further maintenance.
  - b. If backpressure is greater than 40" H<sub>2</sub>O or 3" Hg, follow the DOC Muffler Clean-Out Instructions.

### How to Prevent the DOC Muffler from Plugging

To prevent the DOC Muffler from plugging, the engine must be properly maintained, calibrated, and idling must be minimized. Performance concerns about operating conditions must be resolved before operating again with a cleaned DOC Muffler.



## DOC Muffler Clean-Out Instructions

Operate the vehicle with a high engine load (e.g., maximum highway speed, uphill or on a chassis dynamometer) for 10-15 minutes and recheck the high idle, no load backpressure by repeating steps 2 and 3 of "How to Check Backpressure Instructions".

1. If backpressure is less than 40" H<sub>2</sub>O or 3" Hg, continue to operate the converter without further maintenance.
2. If backpressure is greater than 40" H<sub>2</sub>O or 3" Hg, contact CDG.

## DOC Muffler Disposal Information

DOC Mufflers use a precious metal catalyst to reduce carbon monoxide, hydrocarbons and diesel particulate matter emissions. Typical metals include platinum, palladium and rhodium. These materials can be recycled from damaged or deactivated DOC Mufflers. Please dispose of DOC Mufflers in accordance with local regulations and laws; recycle when possible.

## Limited Warranty

Both the installer and owner should retain a copy of the warranty in their records for the specific vehicle.

## Your Warranty Rights and Obligations

CDG must warrant the diesel emission control system in the application for which it is sold or leased to be free from defects in design, materials, workmanship, or operation of the diesel emission control system which cause the diesel emission control system to fail to conform to the emission control performance level it was verified to, or to the requirements in the California Code of Regulations, Title 13, Sections 2700 to 2706, and 2710, for the periods of time listed below, provided there has been no abuse, neglect, or improper maintenance of your diesel emission control system, vehicle or equipment, as specified in the owner's manuals. Where a warrantable condition exists, this warranty also covers the engine from damage caused by the diesel emission control system, subject to the same exclusions for abuse, neglect or improper maintenance of your vehicle or equipment. Please review your owner's manual for other warranty information. Your diesel emission control system may include a core part (e.g., particulate filter, diesel oxidation catalyst, selective catalytic reduction converter) as well as hoses, connectors, a back pressure monitor (if applicable), and other emission-related assemblies. Where a warrantable condition exists, CDG will repair or replace your diesel emission control system at no cost to you including diagnosis, parts, and labor.

## Warranty Coverage

Warranty coverage begins on the date and mileage when the DOC Muffler Kit is installed by the user and expires when the specified number of years, miles or hours have passed, whichever occurs first.

**Medium Heavy-Duty** 5 years or 100,000 miles  
(170-250 hp / GVWR from 19,500-33,000 lbs.)

**Heavy Heavy-Duty** 5 years or 150,000 miles  
(Exceeds 250 hp / GVWR exceeds 33,000 lbs.)

**Heavy Heavy-Duty** 2 years, unlimited miles  
(Exceeds 250 hp / GVWR exceeds 33,000 lbs. and the truck is 1. typically driven over 100,000 miles per year and, 2. has less than 300,000 miles on the odometer at the time of installation.)

**Off-Road Use** 5 years or 4,200 hours  
(At or above 50 hp )

If any emission-related part of your diesel emission control system is defective in design, materials, workmanship, or operation of the diesel emission control system thus causing the diesel emission control system to fail to conform to the emission control performance level it was verified to, or to the requirements in the California Code of Regulations, Title 13, Sections 2700 to 2706, and 2710, within the warranty period, as defined above, CDG will repair or replace the diesel emission control system, including parts and labor.

In addition, CDG will replace or repair the engine components to the condition they were in prior to the failure, including parts and labor, for damage to the engine proximately caused by the verified diesel emission control strategy. This also includes those relevant diagnostic expenses in the case in which a warranty claim is valid. CDG may, at its option, instead pay the fair market value of the engine prior to the time the failure occurs.

### Installation Warranty Responsibility

The CDG authorized installer must furnish the owner with a copy of the following statement.

### Your Warranty Rights and Obligations

\_\_\_\_\_  
(Installer's name) warrants that the installation of a diesel emission control system is free from defects in workmanship or materials which cause the diesel emission control system to fail to conform to the emission control performance level it was verified to, or to the requirements in the California Code of Regulations, Title 13, Sections 2700 to 2706. The warranty period and the extent of the warranty coverage provided by the installer must be the same as the warranty provided by the product manufacturer, and the same exclusions must apply.

### Owner's Warranty Responsibility

As the vehicle, engine, or equipment owner, you are responsible for presenting your vehicle, engine, or equipment, and diesel emission control system to your CDG installer as soon as a problem with the installation is detected. If you have questions regarding your warranty rights and responsibilities, you should contact

\_\_\_\_\_ (installer's contact)

at \_\_\_\_\_ (installers toll-free phone) or the California Air Resources Board at 9528 Telstar Avenue, El Monte, California 91731, or (800) 363-7664, or electronic mail: [helpline@arb.ca.gov](mailto:helpline@arb.ca.gov).

### Owners Warranty Responsibility

As the (vehicle, engine, equipment) owner, you are responsible for performing the required maintenance described in your owner's manual. CDG recommends that you retain all maintenance records and receipts for maintenance expenses for your vehicle, engine, or equipment, and diesel emissions control system. If you do not keep your receipts or fail to perform all scheduled maintenance, CDG may have grounds to deny warranty coverage. You are responsible for presenting your vehicle, equipment or engine, and diesel emissions control system to a CDG dealer as soon as a problem is detected. The warranty repair or replacement should be completed in a reasonable amount of time, not to exceed 30 days. If a replacement is needed, this may be extended to 90 days should a replacement not be available, but must be performed as soon as a replacement becomes available.

If you have any questions regarding your warranty rights and responsibilities, you should first contact CDG Emissions Retrofit Technical Support toll-free at (866) 817-8733 or the California Air Resources Board at 9528 Telestar Avenue, El Monte, California 91731, or (800) 363-7663, or electronic mail: [helpline@arb.ca.gov](mailto:helpline@arb.ca.gov).

### **Actions and Improper Maintenance That May Result in Denial of Your Warranty Coverage**

The following conditions are considered to be abuse, neglect or improper maintenance that may result in denial of warranty coverage:

- Failure to follow Original Equipment Manufacturer (OEM) maintenance and operating procedures. Proper OEM maintenance and operating procedures are understood to be those procedures recommended by the OEM to ensure engine longevity and operation.
- Excessive particulate emissions due to poor engine operation and maintenance.
- Misapplication to an engine model or to a duty cycle other than that which it is designed and approved.
- Improper installation (strict adherence to the CDG owners manual is required).
- Alterations or attempted repairs.
- Progressive engine failure that allows lube oil, fuel or coolant to be present in the engine exhaust, in excess of OEM specifications.

Use of fuel:

- (a) other than that for which the engine is calibrated or other than recommended by CDG.
- (b) containing other than ultra low sulfur diesel or not approved in writing by CDG, or fuel other than that which is specifically required to achieve the emissions required.
- (c) blended fuel with lube oil, kerosene, fuel additives or other materials not approved in writing by CDG.
- Excessive lube oil consumption.
- Physical damage caused by misuse, abuse or road hazards including (but not limited to) dents, cuts or fractures.

- Damage caused by improper cleaning procedures (failure to adhere to CDG recommended cleaning guidelines).
- Failures or damage caused by mounting system failures.
- Damage to the DPF Section or plugging caused by water entry.



Clean Diesel Group, LLC.  
**Whitmore Lake, MI**  
[www.cleandieselgroup.org](http://www.cleandieselgroup.org)

**Technical Support 866-817-8733**  
[tech@cleandieselgroup.org](mailto:tech@cleandieselgroup.org)

© 2019 Clean Diesel Group, LLC. All rights reserved. Printed in USA

IOM P478598, Revision 3  
February 2014